



## TECHNICAL DATA SHEET

### 400 Series Pneumatic Actuators

2 Otter Court, Raymond, New Hampshire 03077 • Tel. (603) 895-4761 • FAX (603) 895-6785 • www.geminivalve.com



#### DESCRIPTION

The 400 Series actuators are Gemini's legacy line of compact pneumatic automation. The 400 Series may be fitted to all Gemini 76, 86, 96, & 89 Series Valves by means of a rigid, precise mounting system.

#### MATERIALS OF CONSTRUCTION

**BODY, END CAPS:** : Aluminium with Teflon® Impregnated Hard Anodized (PolyLube®) Surfaces

**SPRING MODULES:** Aluminium with Teflon® Impregnated Hard Anodized (PolyLube®) Surfaces

**SHAFT / DRIVER & EXTERNAL TRIM:** 300 Series Stainless Steel

#### RATINGS / SPECIFICATIONS

**TEMPERATURE:** -20°F to 350°F

**POWER:** Models B412D, A422D; 50 - 125 psi air, models B411D, A421D, B412SR, A422SR 75 - 125 psi air. Sufficient air delivery must be available at the actuator to ensure dependable operation. The following precautions should be observed: Air supply should be clean and free of moisture. When dirty or wet air is a problem; a filter / separator should be specified; these units are most effective when installed as closely as possible to the actuator. A filter, when used, should permit a minimum flow of 4 scfm at an upstream pressure of 60 psi. Eliminate severe restrictions to air flow (certain solenoid valves & fittings). The most restricted passage must have an area no smaller than .012 inches square, the area of 1/8" diameter orifice. If more than a single actuator is to be supplied by an individual pilot, the minimum passage requirement applies per actuator.

**TUBING:** For short runs up to 5 feet 5/32" I.D. is suitable, 1/4" I.D. will serve up to 30 feet. For longer runs, use 3/8" I.D. or larger.

---

---

## **RATINGS / SPECIFICATIONS (continued)**

**DUTY CYCLE:** 100%

**CYCLE TIME:** (To Open or Close) Approximately 1/2 to 1 second\*

\* - Dependent upon actuator model, air pressure and delivery

## **MAINTENANCE**

Gemini 400 Series Pneumatic Actuators are designed to be maintenance free and normally are replaced vs. repaired.

**Double-Acting Models:** For double-acting models, rebuilding of the actuator by our *Factory Authorized Service Center* may enable the actuator to be returned to service depending on the duty cycle the actuator has seen. The cost to rebuild the actuator is generally 50% of the cost of a new actuator. For details on this service please contact us. Additionally, for those customer desiring to replace O-rings, gasket(s) and lubricant, we offer o-ring kits which contain these genuine factory components.

**Spring-Return Models:** The 400 Series are not recommended to be rebuilt and should be replaced when they have seen their useful life.

---

---

## ACTUATOR TO VALVE MOUNTING INSTRUCTIONS

### 76, 86 & 96 SERIES VALVES

These instructions detail the procedure for installing a Gemini 400 Series pneumatic actuator on a drive-key equipped Gemini 76, 86 or 96 Series ball valve. Valves may be purchased with the drive-key assembled or may be retrofitted with a drive-key conversion kit.

#### Assemble Bracket to Actuator

1. Position the bracket gasket on the actuator mounting surface so that the alignment pins engage the slots (B410 Series) or holes (A420 Series) in the gasket.

2. Place the bracket, from the mounting kit, on the mounting surface over the gasket so that the alignment pins engage the bracket. In the interest of uniformity, mount the bracket so that the valve locator is on the same side as the actuator inlet ports (or spring module if you are mounting a spring return) as shown in Figure 1.

#### Assemble Valve to Actuator

1. Double Acting Actuators: Check the valve to be sure that it is either completely open or completely shut. Observe the OPEN / SHUT indicator mounted on the actuator shaft; turn the shaft if necessary so that the indicator corresponds to the position of the valve.

Spring Return Actuators: Turn the valve stem to orient the ball in the desired for spring action, i.e. "spring to open" or "spring to close". Observe the OPEN / SHUT indicator mounted on the actuator shaft to assure that it reads correctly. If it does not, remove the two screws which hold the indicator cover and rotate the cover 180 degrees, reinstall the screws.

2. Place the actuator, with the bracket attached, atop the valve so that the 12 point socket engages the stem nut, the shaft notch engages the drive-key and locator engages the valve body hex. If your valve is a Series 86 or 96, the locator must contact the valve body on the side opposite the end plug as shown in Figure 2. If the valve stem nut will not engage the socket in the coupling, reposition the nut slightly (this should require less than 1/12 turn). The valve locator has been preassembled to the bracket to fit your valve; if the valve locator does not engage the hex, or if it

Figure 1

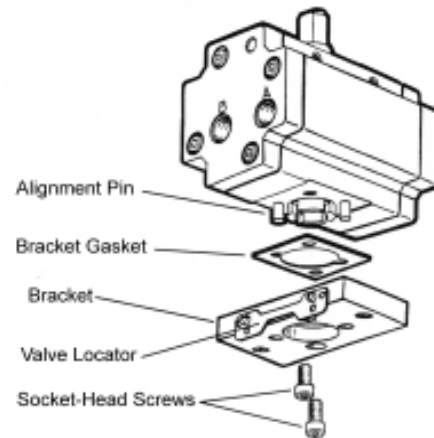
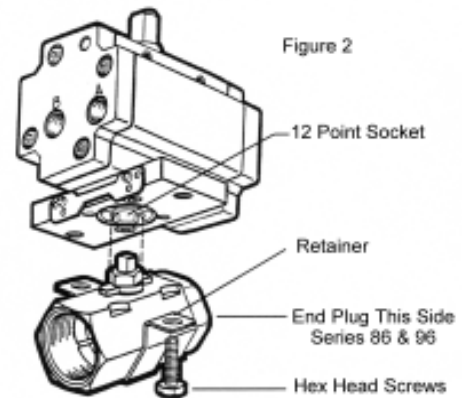

Figure 2



prevents the bracket from contacting the upper surface of the valve body, it must be repositioned.

3. Position the retainer on the underside of the valve and fasten to the actuator bracket with the two hex-head capscrews. Tighten the screws alternately to assure balanced pulldown and to avoid skewing of the actuator bracket on the valve body. Continue tightening only until the actuator is securely anchored. A gap should remain between the lower surface of the bracket and the retainer "ears" when the assembly is complete.

## ACTUATOR TO VALVE MOUNTING INSTRUCTIONS

### 89 SERIES VALVES

These instructions detail the procedure for installing a Gemini 400 Series pneumatic actuator on a drive-key equipped Gemini 89 Series ball valve. Valves may be purchased with the drive-key assembled or may be retrofitted with a drive-key conversion kit.

#### Assemble Bracket to Actuator

1. Position the bracket gasket on the actuator mounting surface so that the alignment pins engage the slots (B410 Series) or holes (A420 Series) in the gasket. See Figure 1; the mounting surface is cross-hatched.
2. Place the bracket, from the mounting kit, on the mounting surface over the gasket so that the alignment pins engage the blind holes in the bracket.
3. Assemble the bracket to the actuator with two fine-thread socket head screws. (The B410 Series uses button-head socket screws; the A420 Series, standard socket head screws.) Tighten securely.

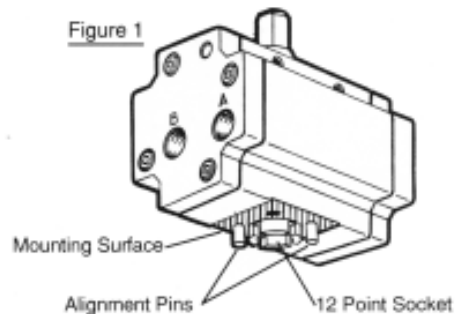

#### Assemble Valve to Actuator

1. Double Acting Actuators: Check the valve to be sure that it is either completely open or completely shut. Observe the OPEN / SHUT indicator mounted on the actuator shaft; turn the shaft if necessary so that the indicator corresponds to the position of the valve.  
Spring Return Actuators: Turn the valve stem to orient the ball in the desired for spring action, i.e. "spring to open" or "spring to close". Observe the OPEN / SHUT indicator mounted on the actuator shaft to assure that it reads correctly. If it does not, remove the two screws which hold the indicator cover and rotate the cover 180 degrees, reinstall the screws.

2. Place the actuator, with the bracket attached, atop the valve so that the 12 point socket engages the stem nut, the shaft notch engages the drive-key. If the valve stem nut will not engage the socket in the coupling, reposition the nut slightly (this should require less than 1/12 turn). Force the actuator and valve together until the actuator bracket bottoms in the valve bracket.

3. Fasten the actuator to the valve with two socket-head mounting screws.

Your Gemini Actuated Valve is now ready for service.

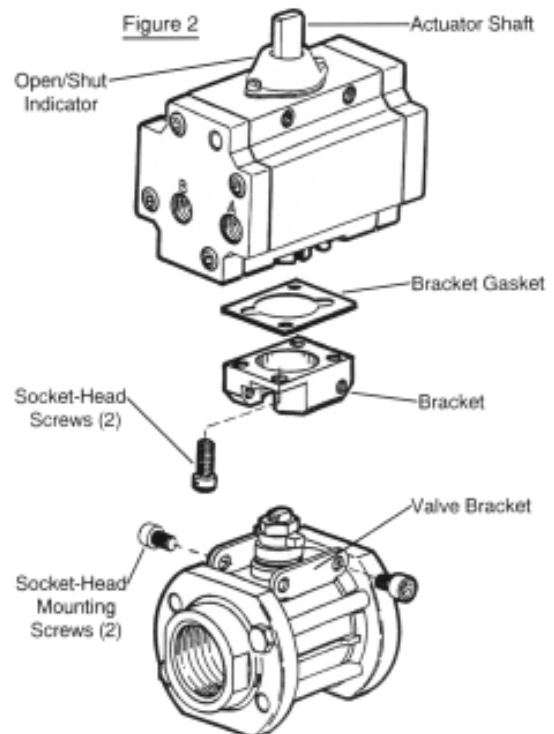

**ACTUATOR TO VALVE SELECTION DATA**

Actuator Models	Suitable for Valve Series & Size				
	76	86	96	89 (Port)	309
B411D B412D B412SR	1/2	1/4& 3/8	-	0.5	1/2
	3/4	1/2	-	0.6	3/4
	1	3/4	1/2	-	-
A421D A422D A422SR	1-1/4	1	3/4	0.8	-
	1-1/2	1-1/4	1	1.0	-
	2	1-1/2	1-1/4	1.2	-
	-	2	1-1/2	1.5	-

# DIMENSIONS

## 76, 86 & 96 SERIES VALVES

Valve Size & Series			Actuator Model			Approximate Dimensions (Inches)																	
76	86	96	Spring-Return 75 - 125 psi	Double-Acting 75 - 125 psi	Double-Acting 50-125 psi	A1	A2	A3	B1	B2	C		D	E	F	G	H	I	J	K	L	M	N
1/2	1/4 & 3/8	-	B412SR	B411D	B412D	7.64	3.64	2.73	5.85	1.85	2.18	2.22	4.26	.50	3.00	1.01	1.25	.19	.86	#10-24	.31	.47	1.31
3/4	1/2	-				2.22	2.61	4.35	.59														
1	3/4	1/2				2.76	2.94	4.51	.75														
1-1/4	1	3/4	A422SR	A421D	A422D	12.20	5.70	4.34	9.11	2.92	3.02	3.32	7.05	.97	4.80	1.59	1.96	.27	1.06	#10-24	.50	.81	2.12
1-1/2	1-1/4	1				3.45	3.70	7.14	1.06														
2	1-1/2	1-1/4				4.04	4.25	7.39	1.31														
-	2	1-1/2	-	-	-	-	-	-	-	-	4.67	7.58	1.50	-	-	-	-	-	-	-	-	-	-

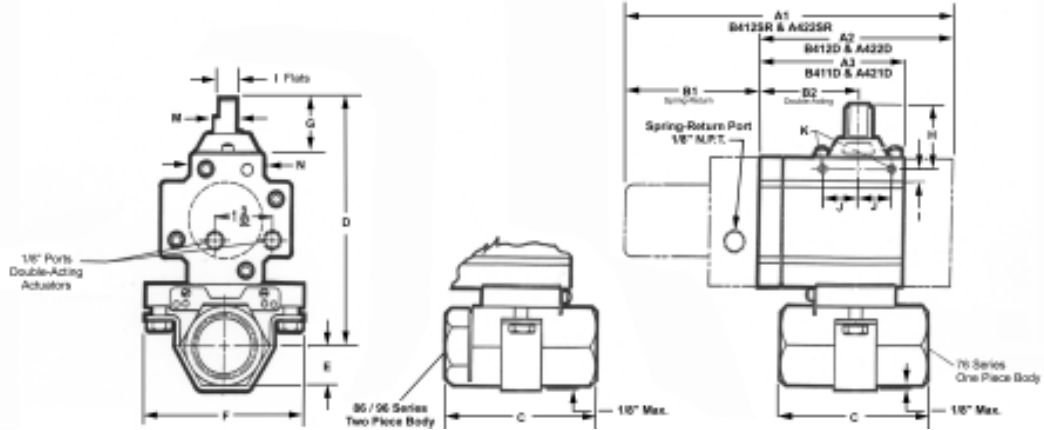

## 89 SERIES VALVES

VALVE SIZE			ACTUATOR MODEL			APPROXIMATE DIMENSIONS (INCHES)																	
STANDARD PORT	FILL PORT	PORT SIZE	ACTUATOR MODEL (SPRING-RETURN)	ACTUATOR MODEL (DOUBLE-ACTING)	ACTUATOR MODEL (DOUBLE-ACTING)	AIR SUPPLY 75 - 125 PSI / AIR SUPPLY 50 - 125 PSI																	
						A1	A2	A3	B SPRING RETURN	B DOUBLE ACTING	C	D	E	F	G	H	J	K	L	M	N	P	Q
1/2	1/4 & 3/8	0.5	B412SR	B411D	B412D	7.64	3.64	2.73	5.85	1.85	1.59	4.11	1.09	2.50	2.38	1.25	.66	#10-24	.31	.47	1.31	1.01	.19
3/4	1/2	0.6	A422SRA	A421DA	A422DA	11.89	5.70	4.34	9.11	2.92	1.69	4.20	1.17	2.75	3.87	1.96	1.06	5/16-18	.50	.81	2.12	1.59	.27
1	3/4	0.8				11.89	5.70	4.34	9.11	2.92	2.28	7.54	1.60	3.75	3.87	1.96	1.06	5/16-18	.50	.81	2.12	1.59	.27
1 1/4	1	1.0				11.89	5.70	4.34	9.11	2.92	2.33	7.87	1.92	4.50	3.87	1.96	1.06	5/16-18	.50	.81	2.12	1.59	.27
1 1/2	1 1/4	1.25	A422SR	A421D	A422D	11.89	5.70	4.34	9.11	2.92	2.56	7.98	2.00	4.75	-	-	-	-	-	-	-	-	-
2	1 1/2	1.50				11.89	5.70	4.34	9.11	2.92	2.56	7.98	2.00	4.75	-	-	-	-	-	-	-	-	-

Valve and Actuator specifications are subject to change without notice and without obligation on the part of the manufacturer.

