



600 Series Electric Actuator Wiring Instructions - DC Models

2 Otter Court, Raymond, New Hampshire 03077 •Tel. (603) 895-4761 •FAX (603) 895-6785 •www.geminivalve.com

These instructions detail the procedure for wiring Gemini 600 Series DC model electric actuators.

1. Unlatch and open the override handle to access the handle nut. Remove nut with 3/4" wrench.
2. Remove eight (8) socket head screws with 4mm hex wrench. Remove cover by pulling straight up.
3. Route the wire to be terminated through conduit hub and up through the access space to the terminal block. Strip insulation back 1/4", insert the stripped ends directly into the proper terminal clamps and tighten screws. All internal connections are labeled in the diagram below.
4. Verify that cover o-ring is properly seated in groove. Replace cover and screws.

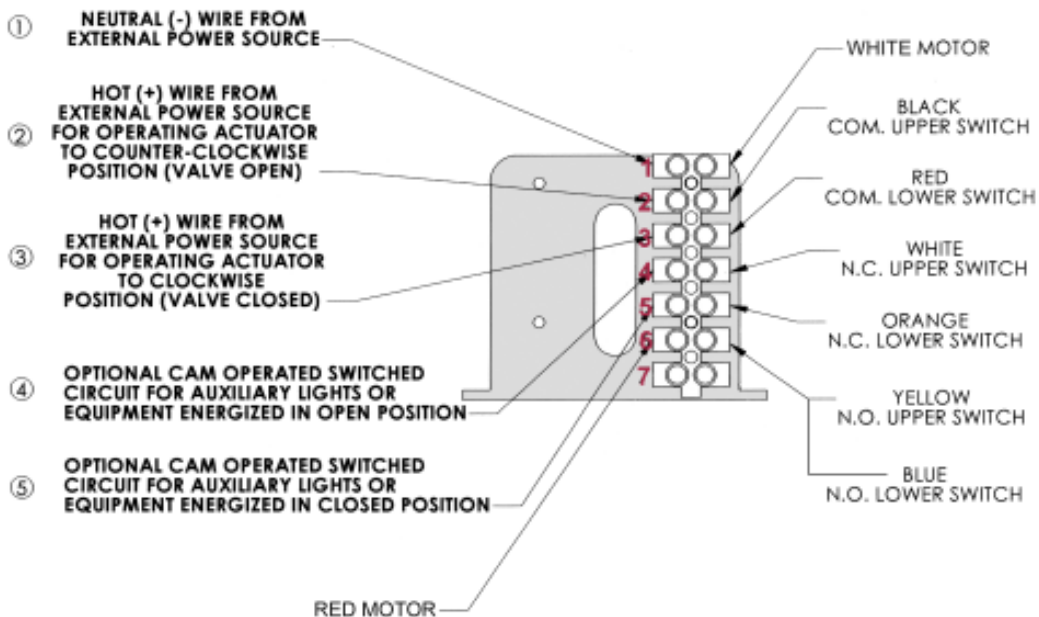
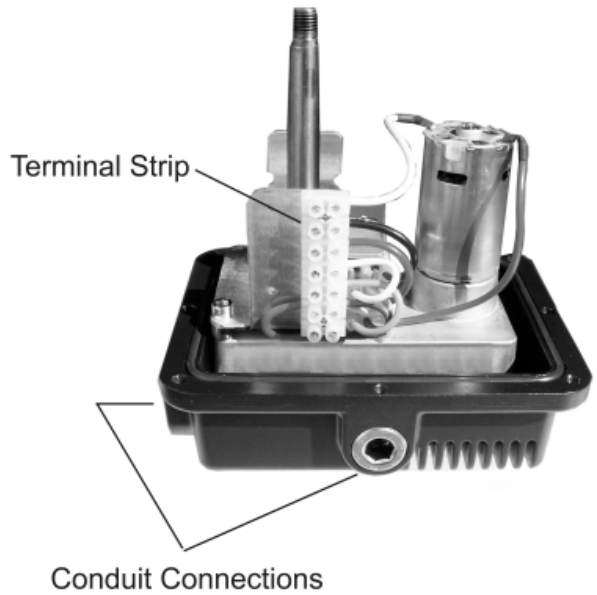

Connections ① through ⑤ are to be made by field electrician

DC Wiring Schematic

